

SUSANNE METAXAS – PARASKEVI TRITSAROLI

## Gathering the Very Young

*A Contribution to Early Byzantine Burial Practices Based on the Contextual Analysis of a Children's Grave Found in Ancient Pallantion (Arcadia, GR)*

*With seven plates*

Abstract: This paper presents a children's grave, found in 2009 during rescue excavations at the settlement of Ancient Pallantion (Arcadia, GR). The grave contained the human remains of five individuals aged between 1 and 5 years, a clay jug, a belt buckle, two earrings and a cross pendant, all dating to the 6<sup>th</sup>–early 7<sup>th</sup> c. This assemblage was examined through an interdisciplinary approach (archaeology & bioarchaeology) that revealed evidence regarding the biological identity and health status of the deceased as well as information concerning children's clothing and burial practices. In this particular grave the individuals—in all probability relatives—consist of primary burials as well as secondary deposits thus possibly displaying the parents' desire to gather the very young. Finally, the age at death of all individuals confirmed the high infant mortality of the first age category (πρώτη ηλικία) that can be caused by infections, injuries, malnutrition, unhygienic living conditions as well as the onset of weaning and its accompanying biological adaptations.

Our knowledge about children in Byzantium is gradually increasing thanks to a growing interest in the stages and diverse aspects of childhood as well as the interdisciplinary approach to this topic.<sup>1</sup> It is based primarily on written sources<sup>2</sup> and enhanced by inscriptions,<sup>3</sup> pictorial representations<sup>4</sup> and by material culture such as toys, jewellery or clothing.<sup>5</sup> More recently, bioarchaeological analyses have focused on a more integrated approach to Byzantine children thus revealing valuable details

<sup>1</sup> Becoming Byzantine. Children and Childhood in Byzantium, ed. A. Papaconstantinou – A.-M. Talbot. Washington 2009, 167–251.

<sup>2</sup> D. ARIANTZI, Kindheit in Byzanz. Emotionale, geistige und materielle Entwicklung im familiären Umfeld vom 6. bis zum 11. Jahrhundert (*Millennium-Studien* 36). Berlin – Boston 2012.

<sup>3</sup> Children are rarely mentioned in inscriptions and if they are, they belong to the middle or upper class, see A.-M. TALBOT, The Death and Commemoration of Byzantine Children, in: *Becoming Byzantine* 302. We add here an inscription from the Early Byzantine Northern cemetery of Argos referring to the death of a girl aged 10 in 536 A.D., see A. OIKONOMOU-LANIADO, Argos paléochrétienne. Contribution à l'étude du Péloponnèse Byzantin (*BAR International Series* 1173). Oxford 2003, 52 no. 3, 161 fig. 116; Βυζαντινό Μουσείο Αργολίδας. Κατάλογος μόνιμης έκθεσης, ed. D. Athanasoulis – A. Vassiliou. Athens 2016, 56, cat. no. 30 (A. VASSILIOU).

<sup>4</sup> For a wall painting from the 4<sup>th</sup> c. depicting two boys (so-called tomb of Eustorgios) see *Everyday Life in Byzantium* (Thessaloniki, White Tower, October 2001 – January 2002), ed. D. Papanikola-Bakirtzi. Athens 2002, 532–533. For a Late Antique mosaic depicting scenes of the life of a boy (Kimbro), see C. MARINESCU – S. E. COX – R. WACHTER, Paideia's Children: Childhood Education on a Group of Late Antique Mosaics, in: *Constructions of Childhood in Ancient Greece and Italy*, ed. A. Cohen – J. B. Rutter (*Hesperia Supplement* 41). Princeton 2007, 101–114. An important new study is provided by C.-M. BEHLING, Kinderdarstellungen in der Spätantike und im frühen Christentum. Untersuchungen der Bildtypen, ihrer Entwicklung und Verwendung (*Phoibos Humanities Series* 5). Vienna 2016.

<sup>5</sup> For a general overview on the Early Byzantine material culture associated with children, see B. PITARAKIS, The Material Culture of Childhood in Byzantium, in: *Becoming Byzantine* 167–251. For children's toys, see *Everyday Life in Byzantium* 493–495, cat. no. 674 (A. DRANDAKI), cat. no. 675 (M. ARGYRIADI), cat. no. 676 (E. PELEKANIDOU – I. MOTSIANOS), cat. no. 677 (A. TSANANA); Βυζαντινό Μουσείο Αργολίδας 195, cat. no. 278 (S. METAXAS). For amulets and jewellery from children's graves, see V. DASEN, Chercher l'enfant! La question de l'identité à partir du matériel funéraire, in: *L'enfant et la mort dans l'Antiquité III. Le matériel associé aux tombes d'enfants*, ed. A. Hermay – C. Dubois (*Bibliothèque d'Archéologie Méditerranéenne et Africaine* 12). Arles 2012, 9–22; S. METAXAS, Schmuck und Kleidungszubehör aus der frühbyzantinischen Nordnekropole von Argos. *Jahrbuch des Römisch-Germanischen Zentralmuseums Mainz* 62 (2015) (forthcoming); Βυζαντινό Μουσείο Αργολίδας 197, cat. nos. 283–284 (S. METAXAS).

on their biological and social status and addressing questions concerning diet, health status, diseases and mortuary treatment.<sup>6</sup>

Archaeology plays an important role in the research on childhood, being a discipline that constantly yields new material through excavations. As the identification of children in archaeological contexts is extremely difficult—their remains are easily confused with animal bones or have even disintegrated due to their fragility—it is primarily realized through the graves of children that can be identified from their small size. Such a grave, found in 2009 during rescue excavations conducted by the former 25<sup>th</sup> Ephorate of Byzantine Antiquities in Ancient Pallantion (Arcadia, GR), is examined in this study.

This grave (Grave 1) and its contents—the human remains of five children, a funeral jug, a belt buckle, two earrings and a cross pendant—provided a unique assemblage for a detailed archaeological and osteological study with the aim of gaining insight into the biological identity and the health status of the deceased, aspects of children’s clothing as well as burial practices and contributing to the research on early childhood from the viewpoint of the Early Byzantine Peloponnese.<sup>7</sup>

## 1. INTRODUCTION

### 1.1. PALLANTION: LOCATION AND EXCAVATIONS

Pallantion is situated in the western part of the plateau of Mantinea (~670 m) in the Peloponnese, about 7 km west of Ancient Tegea and 7 km southwest of Tripoli, the capital of the Arcadia prefecture (pl. 1a). Its archaeological remains were localized at the beginning of the 19<sup>th</sup> c.<sup>8</sup> on the basis of Pausanias’ description of Greece,<sup>9</sup> on the Boreion/Gravari hill (today Hag. Ioannis) as well as in its adjacent plain.

The first systematic excavations were conducted by the Italian School of Archaeology at Athens in 1940, bringing to light monuments and findings dating from the Archaic to the Middle Byzantine period.<sup>10</sup> Only in 2009 were new excavations conducted by the responsible Archaeological Services

<sup>6</sup> M. E. LEWIS, *The Bioarchaeology of Children. Perspectives from Biological and Forensic Anthropology*. Cambridge 2007. For the Byzantine period see P. TRITSAROLI – F. VALENTIN, *Byzantine Burial Practices for Children; Case Studies Based on a Bioarchaeological Approach to Cemeteries from Greece*, in: *Nasciturus, infans, puerulus, vobis mater terra: la muerte en la infancia*, ed. F. G. Jener – S. Muriel – C. Olária. Castellò 2008, 93–113; E. DAVIES, *Byzantine Attitudes Towards Foetuses, Newborn Babies and Infants: A Multidisciplinary Approach*. *Rosetta* 8 (2010) 1–41; C. BOURBOU, “Hide and Seek”: the Bioarchaeology of Children in Byzantine Greece, in: *Themelion. 24 meletes gia ton daskalo Petro Themele apo tous mathetes kai tous synergates tou*, ed. E. P. Sioumpara – K. Psaroudakis. Athens 2013, 465–483. See also D. STATHAKOPOULOS, *Death in the Countryside: Some Thoughts on the Effects of Famine and Epidemics*. *Antiquité Tardive* 20 (2012) 105–114.

<sup>7</sup> Studies concerning human remains from the Early Byzantine Peloponnese are C. BOURBOU, *Health Patterns of Proto-Byzantine Populations (6<sup>th</sup>–7<sup>th</sup> centuries AD) in South Greece: The Cases of Eleutherna (Crete) and Messene (Peloponnese)*. *International Journal of Osteoarchaeology* 13 (2003) 303–313; J. L. RIFE, *Isthmia: The Roman and Byzantine Graves and Human Remains (Isthmia 9)*. Princeton 2012.

<sup>8</sup> *Expédition scientifique de Morée. Recherches géographiques sur les ruines de la Morée*, ed. M. E. Puillon Boblaye. Paris – Strasbourg 1836, 146; L. ROSS, *Reisen und Reiserouten durch Griechenland. Erster Theil: Reisen im Peloponnes*. Berlin 1841, 58–64, esp. 62–63.

<sup>9</sup> Pausanias 8.44.1–6 (ed. M.-H. ROCHA-PEREIRA, *Pausaniae Graeciae Descriptio*, II. Leipzig 1977, 316–318); *RE* 18,3 (1949) 231–234 s. v. Pallantion (E. MEYER); *Griechenland. Lexikon der historischen Stätten. Von den Anfängen bis zur Gegenwart*, ed. S. Lauffer. Munich 1989, 505.

<sup>10</sup> G. LIBERTINI, *Scavi in Arcadia (Agosto-Settembre 1940)*. *Annuario della Scuola Archeologica di Atene e delle missioni italiane in Oriente I–II (1939–1940)* 225–230; G. LIBERTINI, *Chiese bizantine nell’area dell’antica Pallanzio*, in: *Pepragmena tou TH’diethnous byzantinologikou synedriou*, A’. Athens 1955, 250–256. See also E. ØSTBY, *The Temples of Pallantion: Archaeological Collaboration in Arcadia*, in: *The Norwegian Institute at Athens. The First Five Lectures*, ed. Ø. Andersen – H. Whittaker (*Papers from the Norwegian Institute at Athens* 1). Athens 1991, 41–55. An extended excavation report was published in the *Annuario della Scuola Archeologica di Atene e delle missioni italiane in Oriente* 68–69 (1990–1991), see therein esp. A. DE FRANCISCIS, *Gli scavi di Pallantion* 25–52 and M. IOZZO – M. PAGANO *Catalogo degli oggetti* 119–283.

for the purpose of constructing a reservoir for the neighbouring Taka Lake.<sup>11</sup> For the former 25<sup>th</sup> Ephorate of Byzantine Antiquities these rescue excavations (pl. 1b: 1) constituted a unique opportunity for new research on Byzantine Pallantion<sup>12</sup> as our knowledge concerning settlement activity during that period depends entirely on archaeological data due to the absence of written sources between the 2<sup>nd</sup> and 10<sup>th</sup> c.<sup>13</sup>

## 1.2. PALLANTION IN THE EARLY AND MIDDLE BYZANTINE PERIOD

The main monuments excavated in 1940 in the Bataki field, east of the ancient acropolis, proving the existence of an organized settlement during the Early Byzantine period are the foundations of two Early Christian basilicas<sup>14</sup> (pl. 1b: 3–4). Of these two the basilica of Hag. Christophoros (pl. 1b: 4) stands out not only due to its size but also due to its impressive mosaic floor that is dated to the middle or the 2<sup>nd</sup> half of the 6<sup>th</sup> c.<sup>15</sup>

Additional data for the Early Byzantine period came to light during the excavations that were conducted in 2009 in the vicinity of these churches with remains of houses (pl. 1b: 1) covered by a layer of collapsed roof tiles.<sup>16</sup> Findings recovered from this destruction layer, among them imported ceramics and lamps belonging to the 5<sup>th</sup>–6<sup>th</sup> c.,<sup>17</sup> indicate not only the utilization phase but also the collapse and abandonment some time afterwards. Furthermore, graves were located in proximity to these houses and particularly at their northern end (pl. 1b: 2),<sup>18</sup> documenting burials of the Early Byzantine period in the Bataki field for the first time. These graves must belong to the 6<sup>th</sup>–7<sup>th</sup> c., judging from the grave type built of elongated Laconian roof tiles<sup>19</sup> as well as from the study of

<sup>11</sup> For findings brought to light by the former 39<sup>th</sup> Ephorate of Prehistoric and Classical Antiquities (henceforth Ephorate of Antiquities of Arcadia) in the excavation sector H, see ΛΘ' Εφορεία Προϊστορικών και Κλασικών Αρχαιοτήτων, in: 2000–2010. Apo to anaskaphiko ergo ton Ephoreion Archaioyton, ed. M. Andreadaki-Vlazaki. Athens 2012, 124–125 (S. FRITZILAS); S. FRITZILAS, Κατασκευή διώρυγας ταμειυτήρα λίμνης Τάκα. Παλλάντιον. *AD* 64, B2 (2009) 319–324; S. FRITZILAS, Πήλινες σφραγίδες άρτου της Ύστερης Αρχαιότητας, in: Keramike tes ysteres archaiotetas apo ton elladiko choro (3os–7os m. Ch.). Epistemonike synantese, Thessaloniki 12–16 Noembriu 2006, ed. D. Papanikola-Bakirtzi – D. Koussoulakou. Thessaloniki 2010, α', 324–327, 332 fig. 5α–β; G. GRIGORAKAKIS – S. FRITZILAS, Νομίσματα από τις νεότερες ανασκαφές στο Παλλάντιο της Αρκαδίας, in: Το nomisma sten Peloponneso. Nomismatokoopia, eikonografia, kyklophoria, oikonomike istoria apo ten archaioteta eos kai te neotere epoche. Apheromene ste mneme tou Tony Hackens. ST' Epistemonike synantese, Argos 26–29 Maiou 2011 (forthcoming).

<sup>12</sup> D. ATHANASOULIS – A. VASSILIOU, Κατασκευή ταμειυτήρα Τάκας. Αρχαίο Παλλάντιο, θέση Μπατάκι. *AD* 64, B1 (2009) 309–311; S. METAXAS, Νέα αρχαιολογικά στοιχεία για την οικιστική δραστηριότητα στο Παλλάντιον στην πρωτοβυζαντινή εποχή, in: International Conference “The Archaeological Work in the Peloponnese (1st AEPPEL)”, Tripoli, 7–11 November 2012 (forthcoming).

<sup>13</sup> For Pallantion in the Byzantine period, see V. KONTI, Συμβολή στην ιστορική γεωγραφία της Αρκαδίας (395–1209). *Symm* 6 (1985) 115; A. AVRAMEA, Le Péloponnèse du IV<sup>e</sup> au VIII<sup>e</sup> siècles. Changements et persistances (*Byzantina Sorbonensia* 15). Paris 1997, 180 no. 96; V. KONTI – I. ANAGNOSTAKIS – A. LAMBROPOULOU – M. LEONTSINI – A. PANOPOULOU, Ιστορική γεωγραφία της βυζαντινής Πελοποννήσου (395–1210). Οι βυζαντινές θέσεις, ed. V. Konti (forthcoming).

<sup>14</sup> LIBERTINI, Scavi in Arcadia 227–230; LIBERTINI, Chiese bizantine.

<sup>15</sup> P. ASIMAKOPOULOU-ATZAKA, Σύνταγμα των παλαιοχριστιανικών δαπέδων της Ελλάδος, II. Πελοπόννησος – Στερεά Ελλάδα (*Byzantine mnemeia* 7). Thessaloniki 1987, 75–76 no. 19. For the Late Antique/Early Byzantine churches of the Peloponnese see R. SWEETMAN, The Christianization of the Peloponnese: The Topography and Function of Late Antique Churches. *Journal of Late Antiquity* 3.2 (2010) 203–261.

<sup>16</sup> ATHANASOULIS – VASSILIOU, Κατασκευή ταμειυτήρα Τάκας 310–311 εικ. 15–16; METAXAS, Παλλάντιον.

<sup>17</sup> The findings comprise fragments of imported fine wares (African Red Slip Ware Form 104, Phocaean Red Slip Ware Form 3), African imported lamps and their local imitations (Hayes type 31) as well as bases of stemmed glass beakers, see ATHANASOULIS – VASSILIOU, Κατασκευή ταμειυτήρα Τάκας 310–311; METAXAS, Παλλάντιον fig. 5, γ–ε. For identical lamps (Hayes Types 28 & 31) found in 1940, see IOZZO – PAGANO, Catalogo degli ogetti 150, nos. 65–66, fig. 85d. 164 fig. 102b.

<sup>18</sup> ATHANASOULIS – VASSILIOU, Κατασκευή ταμειυτήρα Τάκας 311; METAXAS, Παλλάντιον fig. 3.

<sup>19</sup> Graves built of Laconian roof tiles are in use from Antiquity until the Byzantine era see N. G. LASKARIS, Monuments funéraires paléochrétiens (et byzantins) de Grèce. Athens 2000, 303–304. Unfortunately, there is no systematic research for the

Grave 1 and its findings—presented in this paper. Other Early Byzantine findings that should be mentioned are copper coins of Justinian I (527–565) and Justin II (565–578)<sup>20</sup> as well as one-handled jugs and other pottery sherds dated with reservations to the 6<sup>th</sup>–8<sup>th</sup> c.<sup>21</sup>

From the later 6<sup>th</sup> or early 7<sup>th</sup> c. onwards, the ancient cities and villages of the Peloponnese entered a transitional period (“Dark Ages”), characterized by an interruption of monetary circulation,<sup>22</sup> urban transformations and often an abandoning of settlements in favour of safer places.<sup>23</sup> During the 7<sup>th</sup>–9<sup>th</sup> c. the region of Arcadia was additionally affected by the migration of Slavic tribes,<sup>24</sup> traces of whom have been found in the form of handmade sherds in the Bataki field as well as in the aforementioned houses (pl. 1b: 1),<sup>25</sup> possibly reflecting the practice of reusing the abandoned structures of Early Byzantine settlements by the new settlers.<sup>26</sup>

New archaeological data emerges from the 10<sup>th</sup> c. onwards, when the ruins of the two Early Christian basilicas were restored and dedicated to Hag. Georgios and Hag. Christophoros.<sup>27</sup> With

---

characteristics and findings of Byzantine tile graves but a bibliographical survey reveals that there is an extent use during the 6<sup>th</sup>–7<sup>th</sup> c. For tile graves found in the Peloponnese and dated to the 6<sup>th</sup>–7<sup>th</sup> c. see C. ROEBUCK, *The Asklepion and Lerna (Corinth XIV)*. Princeton 1951, 163 fig. 32; G. TSEKES, *Το Άργος στην παλαιοχριστιανική και μεσοβυζαντινή περίοδο (μια πρώτη προσέγγιση στην τοπογραφία του βυζαντινού Άργους)*. *Danaos* 2 (2001) 96–97, 101; N. TSIVIKIS, *Ο βυζαντινός οικισμός της Μεσσηνίας (300–800 μ. Χ.): Μετάβαση από την αρχαιότητα στον μεσαιώνα* (unpubl. thesis, Univ. of Crete). Rethymno 2016, I, 150–152, 180–193. II, 110–111 fig. 127–129, 152 fig. 190–191, 154 fig. 194, 259 fig. 380, 271 fig. 400; Μαντινεία. Αρχαιολογικός οδηγός, ed. A. Karapanagiotou. Tripoli 2015, 85, 87 fig. 90.

<sup>20</sup> IOZZO – PAGANO, *Catalogo degli oggetti* 222, no. 185. 224, no. 186. 225, no. 193. Coins of the 6<sup>th</sup> c. were also unearthed in 2009 in the excavation sector H, see GRIGORAKAKIS – FRITZILAS, *Νομίσματα*.

<sup>21</sup> IOZZO – PAGANO, *Catalogo degli oggetti* 200–203, nos. 142–150. These jugs and sherds require further examination concerning their typology and dating so that they can be related to the different settlement phases of Pallantion.

<sup>22</sup> In Arcadia coins of the 7<sup>th</sup>–10<sup>th</sup> c. are absent, see KONTI, *Αρκαδία* (n. 13) 93.

<sup>23</sup> This is perceptible through the Chronicle of Monemvasia, recounting e.g. that the inhabitants of Lacedaimonia founded Monemvasia and fled to Sicily, see P. LEMERLE, *La Chronique improprement dite de Monemvasie: le contexte historique et légendaire*. *REB* 21 (1963) 10, l. 41–48; E. KISLINGER, *Regionalgeschichte als Quellenproblem. Die Chronik von Monemvasia und das sizilianische Demenna. Eine historisch-topographische Studie (VTIB 8)*. Wien 2001. For the historical and political reasons for this transformation see J. KODER, *Griechenland im Mittelalter*, in: LAUFFER, *Griechenland* (n. 9) 42–45. Numerous archaeological sites in the province of Arcadia reflect this phenomenon, see KONTI, *Αρκαδία*. An important site of that period is the Andritsa cave, located almost halfway between Argos and Tegea, that served in the late 6<sup>th</sup> or early 7<sup>th</sup> c. as a refuge, see *Andritsa Cave. Fatal Refuge*, ed. L. Kormazopoulou – D. Chatzilazarou. Athens 2005. The findings from the cave are exhibited in the Byzantine Museum of Argolis, see *Βυζαντινό Μουσείο Αργολίδας* (n. 3) 65–77, 133, 151–152, 189, cat. nos. 54–82 (S. METAXAS – D. CHATZILAZAROU), cat. nos. 83–102. 147. 188–190 (L. KORMAZOPOULOU), cat. nos. 267–269 (S. METAXAS – D. CHATZILAZAROU).

<sup>24</sup> For this topic, see (selection): J. KODER, *Zur Frage der slavischen Siedlungsgebiete im mittelalterlichen Griechenland*. *BZ* 71 (1978) 315–331; KODER, *Griechenland im Mittelalter* 42–47; AVRAMEA, *Péloponnèse* (n. 13) 67–104; I. ANAGNOSTAKIS, *Οι Πελοποννησιακοί σκοτεινοί χρόνοι: το σλαβικό πρόβλημα. Μεταμορφώσεις της Πελοποννήσου ή της έρευνας*; in: *Οι metamorphoseis tes Peloponnesou (4os–15os ai.)*. Athens 2000, 19–34.

<sup>25</sup> For the Slavic pottery found in 1940 see LIBERTINI, *Scavi in Arcadia* 227, and IOZZO – PAGANO, *Catalogo degli oggetti* (n. 10) 197–199, nos. 138–141. The initial dating of the pottery to 585 A.D., based on the Chronicle of Monemvasia, is nowadays rejected in favour of a later date, based on comparative data from the Balkans, see T. VIDA – Th. VÖLLING, *Das slawische Brandgräberfeld von Olympia (Archäologie in Eurasien 9)*. Rahden 2000, 14, 23–25 fig. 7; AVRAMEA, *Péloponnèse* 82–85; KISLINGER, *Regionalgeschichte* 88–89. For the new findings of Slavic pottery in Pallantion, see METAXAS, *Παλλάντιον* (n. 12) fig. 6 (with bibliography on the topic of the handmade pottery found in the Peloponnese). Two Slavic cremation cemeteries discovered in 2009–2010 in neighbouring Makri (west of Tripoli) and near Asea, dating to the 8<sup>th</sup>–9<sup>th</sup> c. and the 7<sup>th</sup>–8<sup>th</sup> c. respectively, clearly indicate the presence of Slavic settlers in Arcadia. For findings from these cemeteries, see *Βυζαντινό Μουσείο Αργολίδας* 228–237, cat. nos. 362–366. 368–371 (S. METAXAS), cat. nos. 372–375. 381 (A. VASSILIOU).

<sup>26</sup> Slavic pottery often emerges in abandoned parts of ancient cities, see METAXAS, *Παλλάντιον*.

<sup>27</sup> Both hagionyms have survived as toponyms and served G. Libertini as a starting point for locating the churches. The restoration of the church of Hag. Christophoros in 903 by Nikolaos, bishop of Lacedaimonia is stated by an inscription, see LIBERTINI, *Scavi in Arcadia* (n. 10) 228; LIBERTINI, *Chiese bizantine* (n. 10) 254; D. FEISSEL – A. PHILIPPIDES–BRAAT, *Inventaires en vue d’un recueil des inscriptions historiques de Byzance, III. Inscriptions du Péloponnèse (à l’exception de Mistra)*. *TM* 9 (1985) 300 no. 42, pl. VIII, 2. However, two architectural fragments found in the church of Hagios Christophoros are

the exception of an extant graveyard in the surroundings of the churches probably dating to the 10<sup>th</sup>–12<sup>th</sup>/13<sup>th</sup> c.<sup>28</sup> no traces of an adjacent Middle Byzantine settlement had previously been detected in the area of the Ancient–Early Byzantine settlement of Pallantion.

## 2. AN EARLY BYZANTINE CHILDREN'S GRAVE (GRAVE 1)

### 2.1. ARCHAEOLOGICAL DATA

Grave 1 (pl. 2a–d; 3a) was unearthed at about 30 cm beneath the topsoil at the northern end of the houses<sup>29</sup> (pl. 1b: 1–2). It has the shape of a box and was originally built of 14 square bricks (with a side length of 33 cm and thickness of 4 cm), three tiles for the pavement, the long sides and the cover and one tile for the short sides. Grave 1 was nearly intact with two tiles of the cover missing and two tiles of the southern long side slightly inclined (pl. 2b). The external size of the grave measured 108 cm in length and 44 cm in width, while the internal size was 102 cm in length and 37 cm in width. The height of the grave measured 22–25 cm. The square bricks used for the construction of Grave 1 belong to a well-known Late Roman/Early Byzantine brick type designated for pavements and wall constructions.<sup>30</sup> It was used for the floors of basilicas<sup>31</sup> as well as for funeral architecture like wall constructions, pavements and the coverings of cist graves.<sup>32</sup> Graves built solely of such square bricks and with a flat cover, like Grave 1, constitute a less known grave type<sup>33</sup> in contrast to the graves built of *tegulae* with a triangular cover.<sup>34</sup>

dated to the 11<sup>th</sup> c., see G. P. TSEKES, Βυζαντινή γλυπτική της Αρκαδίας. Από τον έβδομο ως τις αρχές του δέκατου τρίτου αιώνα (unpubl. thesis, Univ. of Thessaly). Volos 2016, I, 207–208. II, 214–215, cat. no. 285–286.

<sup>28</sup> LIBERTINI, Scavi in Arcadia 228. For jewellery found in some of the graves, see IOZZO – PAGANO, Catalogo degli oggetti 248–257, nos. 262–273. 275–280. 283. 287–290. 292–295 (the jewellery is being revisited and prepared for publication by S. Metaxas).

<sup>29</sup> ATHANASOULIS – VASSILIOU, Κατασκευή ταμειυτήρα Τάκας 311 fig. 17; METAXAS, Παλλάντιον fig 4.

<sup>30</sup> S. AMARI, A Late Roman Pottery and Brick Factory in Sicily (Santa Venera al Pozzo), in: Archaeometric and Archaeological Approaches to Ceramics. Papers presented at EMAC'05, 8th European Meeting on Ancient Ceramics, ed. S. Y. Waksman (*BAR International Series* 1691). Lyon 2005 125 fig. 17; J. WITTE-ORR, Bricks and Tiles from the Triangular Tower at Amorium, in: Çanak. Late Antique and Medieval Pottery and Tiles in Mediterranean Archaeological Contexts, ed. B. Böhlerdorff-Arslan – A. O. Uysal – J. Witte-Orr (*Byzas* 7). Istanbul 2007, 298–300; S. WESTPHALEN, Die Basilika am Kalekapi in Herakleia Perinthos. Bericht über die Ausgrabungen von 1992–2010 in Marmara Ereğlisi (*Istanbuler Forschungen* 55). Tübingen 2016, 33 fig. 37.

<sup>31</sup> Th. PAZARAS, Ανασκαφικές έρευνες στην περιοχή της Επανομής Θεσσαλονίκης. Το νεκροταφείο στο Λιμόρι και η παλαιοχριστιανική βασιλική στο Μπριαδούδι (*Byzantina mnemeia* 16). Thessaloniki 2009, 182 fig. 215, 186 fig. 220–221.

<sup>32</sup> ΟΙΚΟΝΟΜΟΥ-ΛΑΝΙΑΔΟ, Argos (n. 3) 124 fig. 40, 126 fig. 42; RIFE, Isthmia (n. 7) 58–61 fig. 2.44; TSIVIKIS, Μεσσήνη (n. 19) I, 183 fig. Σχ.5.3α.2.

<sup>33</sup> The only comparative example, dated to the 8<sup>th</sup> c., is a child's grave that has come to light in Balchik (Bulgaria, Dobrich prov.), see E. KOMATAROVA-BALINOVA, Децата в обществото на средновековните българи (по данни от езическите некрополи) (Children in the Medieval Bulgarian Society based on data from the Pagan Necropolises), in: Eurika. In honorem Ludmilae Donchevae-Petkovae, ed. V. Grigorov – M. Daskalov – E. Komatarova-Balinova. Sofia 2009, 186 fig. 1.

<sup>34</sup> Graves made of *tegulae* and *imbrices* belong to a well-known and widespread grave type dating from the 4<sup>th</sup>–8<sup>th</sup> c., see T. SPRINGER, Unter Dachziegeln zur letzten Ruhe gebettet. Ein spätrömisches Ziegelgrab aus Rheinabern. *MonatsAnzeiger/ Germanisches Nationalmuseum Nürnberg* 204 (1998) 6–9; C. BORCHIA, La sepoltura „alla cappuccina“ di Loppio-S. Andrea (TN). *Annali del Museo Civico di Rovereto* 22 (2006) 23–40, esp. 29–31; H. KASAROĞLU, Parion Nekropolü Mezari Tipleri, in: Doğudan Yükselen Işık Arkeoloji Yazıları, ed. B. CAN – M. IŞIKLI. Istanbul 2007, 505–506 fig. 13. 15–18, 517 fig. 6; P. HNILA, Rural Necropoleis and Settlement Dynamics: Thoughts on Roman and Byzantine graves at Oymağaç Höyük, Samsun province, in: Landscape Dynamics and Settlement Patterns in Northern Anatolia during the Roman and Byzantine Period, ed. K. Winther-Jacobson – L. Summerer (*Geographica Historica* 32). Stuttgart 2015, 148–149, 150 fig. 3, 156–157. For a grave built of square floor bricks, similar to Grave 1, but also with a triangular cover see Ai. ROMIOPOULOU, Νομός Χαλκιδικής. Νέα Συλλάτα. *AD* 31, B2 (1976) 244, pl. 195, ε (the excavator mentions the co-existence of tile graves as well as coins of the emperor Justinian I).

The grave included scattered bones, teeth and fragments of five crania, three (CR1–3) at its western end and two (CR4–5) at its eastern end (pl. 3a). The presence of an intact skeleton (primary burial) cannot be confirmed because of the poor skeletal preservation and significant fragmentation of the remains. However the location of a belt buckle (no. 2), two earrings (nos. 3–4) and a cross pendant (no. 5) in the region of the pelvis and the skull, coinciding with their function as jewellery and a dress accessory, points to the *in situ* position of some skeletal elements including the two crania CR1 and CR5.

It is known from the literature that various intrinsic and extrinsic sources of bias affect the preservation of bones uncovered in archaeological contexts including taphonomic agents, excavation techniques, skeletal maturation, and mortuary practices.<sup>35</sup> As far as the remains of immatures are concerned, it is argued that their bones disappear more rapidly than the remains of adults<sup>36</sup> or that very often they are absent from the cemeteries because their skeletons cannot survive.<sup>37</sup> In addition, geochemical agents related to the soil quality<sup>38</sup> or bone mineralization<sup>39</sup> may impact upon the preservation of the remains. On the other hand, cultural factors related to burial practices can influence the differential preservation of the remains of immatures in archaeological contexts such as the use of burial containers (e.g. pot-burials), the clustering of graves and specialized burial areas in the cemetery, the deposition outside formal burial structures (e.g. in a well) or the unusual concentration of victims of infanticide within non-cemeterial areas.<sup>40</sup> In the following paragraphs we will analyse the preservation and representation of human skeletal remains in order to explore the factors that led to the creation of this funerary assemblage and try to reconstruct the biological profile and mortuary treatment of the deceased.

## 2.2. SKELETAL ANALYSIS

### 2.2.1. Methods

Human skeletal remains were cleaned with water and analyzed macroscopically under normal light conditions. The first step of the analysis was the estimation of the Minimum Number of Individuals (MNI) (pl. 3b); all remains were sorted and recorded as suggested for commingled

<sup>35</sup> C. BOURBOU, Infant Mortality. The Complexity of it all! *Eulimene* 2 (2001) 187–203; E. J. BUIKSTRA – D. C. COOK, Palaeopathology: An American Account. *Annual Review of Anthropology* 9 (1980) 433–470; A. LAGIA, Notions of Childhood in the Classical Polis: Evidence from the Bioarchaeological Record, in: *Constructions of Childhood* (n. 4); S. R. SAUNDERS – R. D. HOPPA, Growth Deficits in Survivors and Non-survivors: Biological Mortality Bias in Subadult Skeletal Samples. *Yearbook of Physical Anthropology* 36 (1993) 127–151; TRITSAROLI – VALENTIN, Byzantine Burial Practices (n. 6) 93–113.

<sup>36</sup> J. L. ANGEL, The Basis of Paleodemography. *American Journal of Physical Anthropology* 30 (1969) 427–438; J. L. ANGEL, The people of Lerna: Analysis of a Prehistoric Aegean Population. Washington 1971, 71.

<sup>37</sup> E. SCOTT, The Archaeology of Infancy and Infant Death (*BAR International Series* 819). Oxford 1999, 109.

<sup>38</sup> C. C. GORDON – J. E. BUIKSTRA, Soil pH, Bone Preservation, and Sampling Bias at Mortuary Sites. *American Antiquity* 46 (1981) 566–571.

<sup>39</sup> H. GUY – C. MASSET – C.-A. BAUD, Infant Taphonomy. *International Journal of Osteoarchaeology* 7 (1997) 221–229.

<sup>40</sup> C. BOURBOU – P. THEMELIS, Child Burials at Ancient Messene, in: *L'enfant et la mort dans l'Antiquité I. Nouvelles recherches dans les nécropoles grecques. Le signalement des tombes d'enfants*, ed. A.-M. Guimier-Sorbets – Y. Morizot (*Travaux de la Maison René-Ginouvès* 12). Paris 2010, 111–128; L. R. GOWLAND – A. T. CHAMBERLAIN, A Bayesian Approach to Ageing Perinatal Skeletal Material from Archaeological Sites: Implications for the Evidence for Infanticide in Roman-Britain. *Journal of Archaeological Science* 29 (2002) 677–685; S. HILLSON, The World's Largest Infant Cemetery and its Potential for Studying Growth and Development: the Notia Kyllindra Site on the Island of Astypalaia in the Dodecanese, in: *New Directions in the Skeletal Biology of Greece*, ed. L. A. Schepartz – S. C. Fox – C. Bourbou (*Hesperia Suppl.* 43). Princeton 2009, 137–154; LAGIA, Notions of Childhood 293–306; L. LITTLE, Babies in Well G5:3: Preliminary Results and Future Analysis. *AJA* 103 (1999) 284 (abstract); P. SMITH – G. KAHILA, Identification of Infanticide in Archaeological Sites: A Case Study from the Late Roman–Early Byzantine Periods at Ashkelon, Israel. *Journal of Archaeological Science* 19 (1992) 667–675; TRITSAROLI – VALENTIN, Byzantine Burial Practices 107.

remains,<sup>41</sup> while visual pair matching complemented by differences in maturation and size, and matching of fragmented pieces and skeletal elements belonging to the same pathological unit were performed.<sup>42</sup> The MNI was estimated by the highest number of frequency of non-matching elements, including duplicate tooth types. In addition, the Bone Representation Index as employed by Bello and Andrews<sup>43</sup> was estimated; this expresses the ratio between the number of observed bones and the theoretical total number of skeletal elements.

Estimation of age was based on standard methods including dental eruption and development,<sup>44</sup> long bone length<sup>45</sup> and fusion of skeletal elements.<sup>46</sup> Four age groups of subadults were adopted as assigned in Buikstra and Ubelaker.<sup>47</sup> Sex determination for immature individuals was not attempted.

Skeletal examination of pathological lesions followed standard data collecting methods.<sup>48</sup> The following lesions were recorded: porotic hyperostosis, abnormal porosity and new bone formation on the cranial vault interpreted as indicators of nutritional deficiencies and deprivation;<sup>49</sup> linear enamel hypoplasia as reflective of developmental stress associated with infectious disease, malnutrition, or other kinds of relatively acute periods of stress and growth arrests in childhood;<sup>50</sup> and periosteal new bone formation as a measurement of inflammatory responses resulting from systemic bacterial infection, localized traumatic injury, or other pathological processes.<sup>51</sup> Skeletal lesions are inventoried by presence-absence, on the basis of true prevalence rates (i.e. number of bones affected by a pathological condition). Several dental<sup>52</sup> non-metric traits were also recorded in order to explore kinship. Dental diseases and non-metric traits are reported by the number of teeth/sockets affected (true prevalence rate) for all observable deciduous and permanent teeth. The percentages reflect the observed (n) over the observable (N). Finally, we used the regression equations proposed by Goodman and Rose<sup>53</sup> in order to estimate the linear enamel hypoplasia formation ages.

<sup>41</sup> J. E. BUIKSTRA – D. H. UBELAKER, Standards for Data Collection from Human Skeletal Remains (*Arkansas Archaeological Survey Research Series* 44). Fayetteville 1994, 9.

<sup>42</sup> H. DUDAY, Contribution des observations ostéologiques à la chronologie interne des sépultures collectives, in: *Anthropologie physique et Archéologie. Méthodes d'étude des sépultures*, ed. H. Duday – C. Masset. Paris 1987, 51–59.

<sup>43</sup> S. BELLO – P. ANDREWS, The Intrinsic Pattern of Preservation of Human Skeletons and its Influence on the Interpretation of Funerary Behaviours, in: *Social Archaeology of Funerary Remains*, ed. R. Gowland – C. Knüsel. Oxford 2006, 1–13.

<sup>44</sup> D. H. UBELAKER, Human skeletal remains: Excavation, Analysis, Interpretation (2<sup>nd</sup> edition). Washington 1989, 64.

<sup>45</sup> M. M. MARESH, Measurements from Roentgenograms: Heart Size, Long Bone Lengths, Bone, Muscles and Fat Widths, Skeletal Maturation, in: *Human Growth and Development*, ed. R. W. McCammon. Springfield 1970, 155–200.

<sup>46</sup> L. SCHEUER – S. BLACK, Developmental Juvenile Osteology. San Diego 2000.

<sup>47</sup> BUIKSTRA – UBELAKER, Standards 9.

<sup>48</sup> BUIKSTRA – UBELAKER, Standards 107–158.

<sup>49</sup> M. E. LEWIS, Endocranial Lesions in Non-adult Skeletons: Understanding their Aetiology. *International Journal of Osteoarchaeology* 14 (2004) 82–97; P. STUART-MACADAM, Porotic Hyperostosis: Representative of a Childhood Condition. *American Journal of Physical Anthropology* 66 (1985) 391–398; D. J. ORTNER – E. H. KIMMERLE – M. DIEZ, Probable Evidence of Scurvy in Subadults from Archaeological Sites in Peru. *American Journal of Physical Anthropology* 108 (1999) 321–331; D. J. ORTNER – W. BUTLER – J. CAFARELLA – L. MILLIGAN, Evidence of Probable Scurvy in Subadults from Archaeological Sites in North America. *American Journal of Physical Anthropology* 114 (2001) 343–351.

<sup>50</sup> S. HILLSON, Teeth (*Cambridge Manuals in Archaeology*). Cambridge 2005, 169–176.

<sup>51</sup> D. A. WESTON, Nonspecific Infection in Paleopathology: Interpreting Periosteal Reactions, in: *A Companion to Paleopathology*, ed. A. L. Grauer. Oxford 2012, 492–512.

<sup>52</sup> K. W. ALT – J. C. TÜRP, Hereditary Dental Anomalies, in: *Dental Anthropology: Fundamentals, Limits and Prospects*, ed. K. W. Alt – F. W. Rösing – M. Teschler-Nicola. Vienna 1998, 95–128; A. CORREIA – C. PINA, Tubercle of Carabelli: a Review. *Dental Anthropology* 15 (2002) 18–21; HILLSON, Teeth 272–285; T. LAUC, Influence of Inbreeding on the Carabelli Trait in a Human Isolate. *Dental Anthropology* 16 (2003) 65–72; G. R. SCOTT – C. G. TURNER II, The Anthropology of Modern Human Teeth: Dental Morphology and its Variation in Recent Human Populations. Cambridge 1997; C. G. TURNER II – C. R. NICHOL – G. R. SCOTT, Scoring Procedures for Key Morphological Traits of the Permanent Dentition: The Arizona State University Dental Anthropology System, in: *Advances in Dental Anthropology*, ed. M. A. Kelley – C. S. Larsen. New York 1991, 13–31.

<sup>53</sup> H. A. GOODMAN – J. C. ROSE, Dental Enamel Hypoplasias as Indicators of Nutritional Status, in: *Advances in Dental Anthropology* 279–294.

### 2.2.2. Results

The MNI included in the grave is five. The non-matching teeth and bones with the highest frequency are the deciduous upper right first molars, the deciduous upper left second molars, the deciduous upper left canines, and left femora. A total of 79 teeth are recorded in the grave.<sup>54</sup> In terms of maturation, the sample comprises 46 deciduous and 33 permanent teeth. Dental age estimation, including entire overlapping maxillae and isolated tooth counts, shows the presence of two 1–2-year old infants (i.e. b–3 years age class) and three 3–5-year old children (i.e. 3–12 years age class). The ages obtained by the fusion of skeletal elements (e.g. vertebrae) fall within this range. The diaphyseal length of one intact left femur is 141 mm, which corresponds to the age of 1–1.5 years.

Bone completeness and surface preservation is moderate. Crania, os coxae and lower limbs are represented at over 50% while the rest of the bones and groups of bones are poorly represented (pl. 3b). Although complete individuation was not attempted due to the preservation state of the remains, it is interesting to note that a pair of maxillae and several post-cranial elements are precisely aged at about 4 to 5 years thus probably belonging to the same individual. Since skeletal completeness may be indicative of the type of deposit in this grave, we can assume that at least one of the children was interred in the tomb as a primary burial.

Regarding dental diseases, 5 of 45 observable teeth with completed crown development (11.1%) display linear enamel hypoplasia; the lesion is recorded on the permanent dentition and affects three molars (pl. 4a) and two premolars. Regression equations for the estimation of linear enamel hypoplasia formation ages show that the individuals who displayed this lesion underwent an episode of stress between 2.2 and 5.3 years. Teeth are not affected by caries. As far as dental non-metric traits are concerned, 11 cases of Carabelli's trait occurred on the deciduous and permanent upper molars (N=14) including four first permanent molars (pl. 4a), two second permanent molars, and five second deciduous molars. Bearing in mind the non-matching teeth preserved and the associated dental arches, it seems that at least four individuals present this trait, some of them conjointly in their deciduous and permanent dentitions.

Cranial lesions include four pathological cases. Abnormal porosity affects the outer table of the occipital of cranium CR4 that is adjacent to the right lambdoid suture; no hypertrophy was observed. New bone formation covering the exterior surface of the right temporal bone associated with the overlying *Temporalis* muscle is recorded for cranium CR5 (pl. 4b). Finally, endocranial lesions of the occipital bone affect crania CR1 and CR2 (pl. 4c). The frontal bone was not preserved in any of the crania.

Post-cranial lesions are displayed on the lower limbs. In particular, porosity is noted on two of eight femora and one of four tibiae. On the femora, the lesion affects the anterior surface in the middle of the diaphysis and on the tibia it occurs on the anterior surface (medial aspect) (pl. 4d). Abnormality of shape in the form of flared distal metaphysis (pl. 4e) and anteroposterior incurvation (pl. 4f) is noted on the only intact, left femur.

### 2.3. THE FINDINGS

(ABBREVIATIONS: D=DIAMETER, H=HEIGHT, L=LENGTH, T=THICKNESS, W=WIDTH)

In Grave 1 five objects were recovered (pl. 3a): a clay jug (no. 1), a copper alloy belt buckle (no. 2), two silver earrings (nos. 3–4) and a silver-plated cross pendant (no. 5). While the clay jug is related to funeral practices, the metal objects are remnants of the children's clothing and adornment.

<sup>54</sup> Excavation techniques can influence the preservation of the remains, although in the case of Grave 1 the filling of the grave was collected and carefully sieved so that all bones and teeth placed in the grave were recovered. As such, the preservation bias due to excavation techniques is limited. Most teeth were recovered without jaws.



### 2.3.1. Clay jug (no. 1)

In the western end of the grave, in its right corner and beside the cranial fragments CR1–3 (pl. 2c; 3a) stood a nearly complete one-handed clay jug with a bell-shaped body and an incised waved decoration on its shoulder (pl. 5a).<sup>55</sup> One-handed clay jugs, abundant in Early Byzantine cemeteries,<sup>56</sup> are in all probability connected to Christian burial practices like sprinkling liquids, e.g. *myron*, on the deceased.<sup>57</sup>

The jug from Pallantion is unique among the known types of Early Byzantine funeral vessels, which exclusively occur in graves.<sup>58</sup> However, it has identical counterparts in the Northern cemetery of Argos (6<sup>th</sup>–early 7<sup>th</sup> c.) illustrating that they also resemble a standardized shape of funeral vessels, maybe regional (pl. 6e). Finally, it is worth mentioning that such jugs predominantly occur in cist graves of the middle class, but rarely or never in tile graves and the earth pits of the poor,<sup>59</sup> which may reflect the social status of the deceased.

### 2.3.2. Copper alloy belt buckle (no. 2)

About 5 cm below the cover and approximately in the middle of the grave (pl. 3a), a miniature belt buckle consisting of an ovoid loop without a plate was unearthed (pl. 5b).<sup>60</sup> Such simple belt buckles are common for the period between the 4<sup>th</sup>–7<sup>th</sup> c. but its tongue with a biconical tip and a basal rectangle resembles a technological feature that appears on Early Byzantine belt buckles in the 6<sup>th</sup> c.<sup>61</sup> This date is also revealed by its co-findings (clay jug, earrings, cross pendant) dating to the 6<sup>th</sup>–early

<sup>55</sup> Wheel-made jug of fine, reddish yellow clay (5YR6/8) with frequent sparkling and white inclusions and with wash; flat base, bell-shaped body with a sharp-edged shoulder, an elongated narrow neck flaring towards the mouth, a flattened rim (broken) and a vertical strap handle; combed decoration consisting of parallel and wavy shallow grooves; H 14.6 cm; D base 8.9 cm; D shoulder 6.9 cm; D rim 4.9 cm; D neck 3 cm; W handle 1.4 cm.

<sup>56</sup> LASKARIS, *Monuments funéraires* (n. 19) 324–325. For funeral vessels from Early Byzantine cemeteries in southern Greece, see the proceedings of the conference *Keramike tes ysteres archaiotetas* (n. 11), therein esp. E. TZAVELLA, *Κεραμική από αθηναϊκού τάφου του τέλους της Αρχαιότητας και οι μαρτυρίες της για τον 7<sup>ο</sup> αι. στην Αττική 649–670*; E. GKINI-TSOFOPOULOU – A. G. YANGAKI, *Παλαιοχριστιανικό νεκροταφείο στη θέση „Δρίβλα“, Πόρτο Ράφτη: μια πρώτη προσέγγιση της κεραμικής 689–711*; K. SKARMOUTSOU, *Κεραμική από παλαιοχριστιανικό νεκροταφείο περιοχής Κρανείου – Αρχαίας Κορίνθου 712–742*. See also *Βυζαντινό Μουσείο Αργολίδας* (n. 3) 34, cat. no. 5. 49–52, cat. nos. 34–39 (A. VASSILIOU); A. YANGAKI, *Οι τάφοι*, in: *Protobyzantine Eleutherna*, Tomeas I, ed. P. Themelis. Athens 2004, 139–142.

<sup>57</sup> Ph. KOUKOULES, *Βυζαντινών βίος και πολιτισμός IV (Collection de l'Institut Français d'Athènes 73)*. Athens 1951, 189; G. D. R. SANDERS, *Archaeological Evidence for Early Christianity and the End of Hellenic Religion in Corinth*, in: *Urban Religion in Roman Corinth: Interdisciplinary Approaches*, ed. D. N. Schowalter – S. J. Friesen (*Harvard Theological Studies* 53). Cambridge 2005, 436 mentions the use of water, wine and oil in modern orthodox practices; N. POULOU-PAPADIMITRIOU – E. TZAVELLA – J. OTT, *Burial Practices in Byzantine Greece: Archaeological Evidence and Methodological Problems for its Interpretation*, in: *Rome, Constantinople and Newly-Converted Europe. Archaeological and Historical Evidence*, vol. 1, ed. M. Salamon – M. Wołoszyn – A. Musin – P. Špehar. Krakow – Leipzig – Rzeszow – Warsaw 2012, 380.

<sup>58</sup> Most jug types are found only in graves and not in house contexts, thus reflecting production exclusively for funerals. For this topic see P. PETRIDIS, *Πρωτοβυζαντινή κεραμική του ελληνικού χώρου*. Athens 2013, 93–94; P. PÉTRIDIS, *Céramique proto-byzantine intentionnellement ou accessoirement funéraire?*, in: *Atti del IX Congresso internazionale sulla ceramica medievale nel Mediterraneo*, Venezia, Scuola Grande die Carmini. Auditorium Santa Margherita, 23–27 novembre 2009, ed. S. Gelichi. Florence 2012, 423–428.

<sup>59</sup> In Argos, but also in the Early Byzantine cemeteries of other sites such clay jugs are regularly found in cist graves but not in tile graves, see METAXAS, *Schmuck* (n. 5). However, there are exceptions, see for instance YANGAKI, *Τάφοι* 125, 163 fig. 50–52; 133, 178 fig. 114–117.

<sup>60</sup> Copper alloy; cast in two pieces; ovoid hoop with D-shaped cross section and tapering ends; suspended tongue with biconical tip and basal rectangle; Hoop: H 2.9 cm, W 1.5 cm, T 0.3 cm. Tongue: L 2 cm, W 0.4 cm, H 0.7 cm.

<sup>61</sup> For this specific tongue (Höckerdorn), see M. SCHULZE-DÖRRLLAMM, *Byzantinische Gürtelschnallen und Gürtelbeschläge im Römisch-Germanischen Zentralmuseum Mainz, Teil 1. Die Schnallen ohne Beschläg, mit Laschenbeschläg und mit festem Beschläg des 5. bis 7. Jahrhunderts (Kataloge Vor- und Frühgeschichtlicher Altertümer 30,1)*. Mainz 2009, 82–83, 229.

7<sup>th</sup> c. Finally, a similar miniature belt buckle was found in the Andritsa cave in the Argolis (pl. 6b) coming from a closed assemblage dated between the late 6<sup>th</sup> and early 7<sup>th</sup> c.<sup>62</sup>

There are indications, that this belt buckle belonged to the individual associated with cranial fragment CR1. Firstly, both were found at the uppermost part of the grave (pl. 5c). Second, the distance between the buckle and the top of cranium CR1 (ca. 25–30 cm) as well as the buckle's orientation with the tongue pointing towards the left side, coincides with its function as a male dress accessory in the region of the pelvis<sup>63</sup> (a left ischium with green coloration could well belong to this individual). We therefore suggest that this small belt buckle girded the tunic (pl. 7a–b) of a young boy<sup>64</sup> whose dental age is estimated at 3–5 years.

### 2.3.3. Silver alloy earrings (no. 3–4)

During the recovery of the cranial fragments CR4–5 (pl. 3a), that were found close together, two silver alloy earrings were unearthed. Both belong to an earring type predominant in the 6<sup>th</sup> c., having the shape of a hoop made of round wire with its ends tapering in a hook and in an Ω-shaped eyelet.<sup>65</sup> They vary slightly in shape with the one (pl. 5d)<sup>66</sup> being entirely round and the other (pl. 5e)<sup>67</sup> having bends in the upper part. These earrings together with those found in Argos<sup>68</sup> (pl. 6c–d) and Olympia,<sup>69</sup> illustrate the abundance of this specific earring type in the Early Byzantine Peloponnese.

Although they are not identical in shape, which is usually the rule for this type, these earrings constituted a pair and can be related to the individual associated with cranial fragments CR5. The cranial fragments still retain green staining from copper corrosion products in the region of both ears (temporal bone) (pl. 5f), indicating the composition of silver alloy since silver used to be alloyed

<sup>62</sup> Βυζαντινό Μουσείο Αργολίδας 78 cat. nos. 73–74, 193 cat. nos 267–269 (D. CHATZILAZAROU – S. METAXAS). Some of the buckles belong to Group A of Schulze-Dörrlamm's typology, see SCHULZE-DÖRRLAMM, Gürtelschnallen 6–35.

<sup>63</sup> M. G. PARANI, Defining Personal Space: Dress and Accessories in Late Antiquity, in: Objects in Context, Objects in Use. Material Spatiality in Late Antiquity, ed. L. Lavan – E. Swift – T. Putzeys (*Late Antique Archaeology* 5). Leiden – Boston 2007, 504–505; E. MARKI, Η αμφίεση στους παλαιοχριστιανικούς και πρωτοβυζαντινούς χρόνους σε μνημεία της Θεσσαλονίκης. *DChAE* 30 (2009) 295; SCHULZE DÖRRLAMM, Gürtelschnallen 2–3; M. SCHULZE-DÖRRLAMM, Byzantinische Gürtelschnallen und Gürtelbeschläge im Römisch-Germanischen Zentralmuseum, Teil II. Die Schnallen mit Schamierbeschläge und die Schnallen mit angegossenem Riemendurchzug des 7. bis 10. Jahrhunderts (*Kataloge Vor- und Frühgeschichtlicher Altertümer* 30,2). Mainz 2009, 293–302.

<sup>64</sup> For Byzantine children's tunics from Egypt see PITRAKIS, Material culture (n. 5) 178–186; S. TSOURINAKI, Ένας παιδικός χιτώνας στην κοπτική συλλογή του Μουσείου Μπενάκη. *Archaiologia & Technes* 83 (2002) 29–36; Die Welt von Byzanz – Europas östliches Erbe. Glanz, Krisen und Fortleben einer tausendjährigen Kultur, ed. L. Wamser. München 2004, 272–273 cat. no. 410 (C. FLUCK); Wege nach Byzanz, ed. B. Fourlas – V. Tsamakda. Mainz 2011, 292 cat. no. III.3.1. (P. LINSCHIED). For the depiction of boys with a knee-length, girded tunica, see Everyday Life in Byzantium (n. 4) 532–533; BEHLING, Kinderdarstellungen (n. 4), 212 fig. 54, 213 fig. 57–58.

<sup>65</sup> For a detailed description of the type (with bibliography), see METAXAS, Schmuck (n. 5).

<sup>66</sup> Silver alloy; solid wire with round cross section; rounded hoop thickening in the lower part and tapering in a hook and an Ω-shaped eyelet; H 1.9 cm, W 2.0 cm, T 0.2 cm. This earring was accidentally collected with cranial fragment CR4, on its right side (but belonging to the left side of CR5).

<sup>67</sup> Silver alloy; solid wire with round cross section; rounded hoop thickening in the lower part, bends in the upper part and tapering in a hook and a probably in an Ω-shaped eyelet (not preserved); H 2.1 cm, W 2.3 cm, T 0.3 cm.

<sup>68</sup> S. METAXAS, Κοσμήματα και εξαρτήματα ένδυσης από το πρωτοβυζαντινό βόρειο νεκροταφείο του Άργους, in: 35<sup>o</sup> Symposio byzantines kai metabyzantines archaiologias kai technes. Programma kai perilepseis eisegeseon kai anakoinoseon. Athens 2015, 76–77; METAXAS, Schmuck nos. 4, 6, 9, 15, 19, 21, 24–25, 34, 36, 40, 43–45, 49, 51, 56.

<sup>69</sup> H. PHILIPP, Bronzeschmuck aus Olympia (*Olympische Forschungen* 13). Berlin 1981, 135 no. 488–490, pl. 7 (no. 488), pl. 41 (nos. 488–489); Th. VÖLLING, The Last Christian Greeks and the First Pagan Slavs, in: The Dark Centuries of Byzantium (7<sup>th</sup>–9<sup>th</sup> c.), ed. E. Kountoura-Galake. Athens 2001, 308, 319 fig. 4 (assemblage found in Grave 21); A. RETTNER, Grabfunde aus Olympia, in: Die Welt von Byzanz 381, cat. no. 876.

with copper.<sup>70</sup> As pairs of earrings are female indicators<sup>71</sup> we identify this individual as a girl, aged between 1.5 and 5 years (the age estimation cannot be more precise because of the scarcity of the remains).

#### 2.3.4. Silver-plated cross pendant (no. 5)

From the soil beneath the crania CR4–5 (pl. 3a), a tiny pectoral silver-plated cross was recovered (pl. 5g).<sup>72</sup> Typological parallels for this cross type can be found in collections<sup>73</sup> but it seems to have been a common type in the Peloponnese: one cross was found in the Early Byzantine Northern cemetery of Argos (pl. 6a) in a cist grave, together with a single earring of the type mentioned above,<sup>74</sup> while another cross of this type comes from an Early Byzantine cist grave in Olympia.<sup>75</sup> Only from the 6<sup>th</sup> c. onwards do such crosses—the new Christian amulets—appear in graves and begin to gradually replace the diverse pagan amulets used before.<sup>76</sup>

The fact that this cross was found in the soil beneath the crania reveals that it was worn around the neck. Unfortunately, it was not possible to determine whether this cross belonged to the girl associated with CR5 or to the individual associated with CR4. Most archaeological evidence for young girls exists due to additional gender-specific jewellery usually found in their graves,<sup>77</sup> which is why we cannot exclude the possibility that the silver earrings and the silver-plated cross pendant constituted a girl's jewellery ensemble.

### 3. SYNTHESIS OF ARCHAEOLOGICAL AND OSTEOLOGICAL DATA

#### 3.1. THE EARLY BYZANTINE SETTLEMENT OF PALLANTION

Grave 1 constitutes an important new assemblage documenting human activity in the settlement of Pallantion during the Early Byzantine period,<sup>78</sup> since graves were previously known only for the

<sup>70</sup> Addition of copper makes the silver alloy harder, lowers the melting point and makes it more resistant to wear, see J. M. CRO-  
NLYN, *The Elements of Archeological Conservation*. London 1990, 17; V. COSTA, The deterioration of silver alloys and some  
aspects of their conservation. *Review in Conservation* 2 (2001) 18–34.

<sup>71</sup> This reveals not only from grave findings but also from pictorial sources, in which women are regularly depicted with pairs  
of earrings, see I. BALDINI LIPPOLIS, *L'oreficeria nell'impero di Costantinopoli tra IV e VII secolo (Biblioteca Archeologica*  
7). Bari 1999, 44 fig. 19a, 48 fig. 22a, 49 fig. 23, 57 fig. 33a, 69 fig. 44–46, 72 fig. 47–48.

<sup>72</sup> Copper alloy, silver-plated; hammered, cut; triangular arms with the upper arm continuing in a narrow, twisted lug; punched  
grooves on the edges of the arms; H 1.9 cm, W 1.2 cm, T 0.2 cm. See also METAXAS, *Schmuck* (n. 5).

<sup>73</sup> W. M. FLINDERS PETRIE, *Amulets*. London 1914, 32, pl. XXIII, 137f; *Byzanz. Das Licht aus dem Osten. Kult und Alltag*  
im Byzantinischen Reich vom 4.–15. Jahrhundert, ed. Ch. Stiegemann. Mainz 2001, 305 cat. no. IV.28.13; *Monuments of*  
*Byzantine Applied Arts 4<sup>th</sup>–7<sup>th</sup> Centuries*, ed. V. Zalesskaya. Saint Petersburg 2006, 129 cat. no. 237.

<sup>74</sup> METAXAS, *Schmuck* no. 3; *Βυζαντινό Μουσείο Αργολίδας* (n. 3) 186, cat. no. 256 (S. Metaxas).

<sup>75</sup> A. FURTWÄGLER, *Die Bronzen und die übrigen kleineren Funde von Olympia*. Berlin 1890, I, 209 no. 1340, refers to a small  
silver cross with punched edges (without figure).

<sup>76</sup> PITARAKIS, *Material Culture* (n. 5) 202–203; Á. BOLLÓK, *Apotropaion and Burial in Early Byzantium: Some Preliminary*  
*Considerations*, in: *Byzanz und das Abendland: Begegnungen zwischen Ost und West*, ed. E. Juhász. Budapest 2013,  
227–241; Á. BOLLÓK, *The „Phylactery of the Cross” and Late Antique/Early Medieval Mortuary Practices in the Eastern*  
*Mediterranean and on its Fringes*, in: *GrenzÜbergänge. Spätromisch, frühchristlich, frühbyzantinisch als Kategorien der historisch-archäologischen*  
*Forschung an der mittleren Donau*, ed. I. Bugarski – O. Heinrich-Tamáská – V. Ivanišević – D. Syrbe  
(*Forschungen zu Spätantike und Mittelalter* 4). Remshalden 2016, 215–230.

<sup>77</sup> For a necklace consisting of a bone cross and bone beads found in an Early Byzantine child's grave, see RIFE, *Isthmia* (n. 7)  
108 no. 20, 110 fig. 2.102–2.103. Most crosses from girls' graves are from the Middle Byzantine period, see PITARAKIS,  
*Material Culture* 202–203 (with bibliography).

<sup>78</sup> See note 28 above. Human activity during the 5<sup>th</sup>–early 7<sup>th</sup> c. is documentable in most ancient villages and cities of Arcadia,  
see KONTI, *Αρκαδία* (n. 13); AVRAMEA, *Péloponnèse* (n. 13) 178–184 nos. 81–153.

Middle Byzantine period. Furthermore, the findings from Grave 1, as well as all other findings unearthed in 1940 and 2009, illustrate Pallantion's access to trade goods and everyday objects which is explained by its location in the immediate vicinity of the major route that connected the hinterland of the Peloponnese to the city of Argos<sup>79</sup> (pl. 1a). The funeral jug (no. 1) (pl. 5a), the earrings (no. 3–4) (pl. 5d–e) and the cross pendant (no. 5) (pl. 5g) found in Grave 1 most certainly originated from Argos, where they have identical counterparts (pl. 6a,c–e).<sup>80</sup>

Due to the fact that the size and the boundaries of Pallantion in the Early Byzantine period are unknown and due to the sparse excavations conducted so far, it was impossible to investigate any evidence regarding cemetery landscape. Nevertheless, the fact that the graves were located near houses with a destruction layer could well reflect the practice of using abandoned places for burials from the 6<sup>th</sup> c. onwards.<sup>81</sup> This assumption may be confirmed through the findings of Grave 1 dating to the 6<sup>th</sup>–early 7<sup>th</sup> c. and also through its co-existence with tile graves, resembling a grave type occurring in abundance in cemeteries of the 6<sup>th</sup>–7<sup>th</sup> c.<sup>82</sup> At this point it is worth mentioning the *tombe a cappuccina costituiti da grandi tegole ma quasi assolutamente privi di corredi funebri* that Guido Libertini found in the Bataki field in 1940 and dated as Classical-Hellenistic based on limited previous archaeological evidence concerning this grave type.<sup>83</sup> On the basis of the new evidence we cannot exclude the possibility that these graves resembled the characteristic Early Byzantine tile graves.

What we can hypothesise up to now based on the graves located in 2009, is that the area of the Bataki field was already used in the Early Byzantine period for burials. In that regard we should acknowledge the proximity of the graves to the Early Christian basilicas (pl. 1b), possibly indicating the practice of burying the dead near churches.

### 3.2. FUNERARY PRACTICES

Grave 1 being E-W orientated and containing a funeral jug (pl. 5a) allowed us to connect it with common Christian burial practices. However, the construction of Grave 1 so far does not resemble a common grave type of Early Byzantine cemeteries, but we must acknowledge that graves made of cheaper materials, like bricks and tiles, are still insufficiently studied and less published as opposed

<sup>79</sup> G. D. R. SANDERS – I. K. WHITBREAD, Central places and major roads in the Peloponnese. *ABSA* 85 (1990) 339 fig. 2, 343 table 4; AVRAMEA, Péloponnèse 109 Pl. IX. For remains of this road near Pallantion see G. ΠΙΚΟΥΛΑΣ, The Road-Network of Arkadia, in: *Defining Ancient Arcadia*, ed. Th. H. Nielsen – J. Roy (*Acts of the Copenhagen Polis Centre* 6). Copenhagen 1999, 272–273 nos. 22–23; Μ. ΠΕΤΡΟΠΟΥΛΟΣ, Αρκαδία. Ιστορικό και αρχαιολογικό περίγραμμα, in: *Archaologia-Peloponnesos*, ed. A. Vlachopoulos. Athens 2012, 230–231 fig. 443. For the route Argos – Tegea see W. K. PRITCHETT, Studies in Ancient Greek Topography, Part III (Roads) (*Classical Studies* 22). Berkeley – Los Angeles – London 1980, 57 fig. 5, 82 fig. 6. To be precise, Tegea could be reached from Achladokampos (Ancient Hysiai) by three different roads, see A. PETRONOTIS, Ἡ τὰ μάλιστα λεωφόρος (Pausanias 8.54.5) in Arkadia, in: *Ancient Arcadia. Papers from the Third International Seminar on Ancient Arcadia*, Held at the Norwegian Institute at Athens, 7–10 May 2002, ed. E. Østby (*Papers from the Norwegian Institute at Athens* 8). Athens 2005, 185–196.

<sup>80</sup> For Argos and its economic activity during the Early Byzantine period, see C. ABADIE-REYNAL, Argos from the Fourth to Eight Centuries, in: *Heaven & Earth. Cities and Countryside in Byzantine Greece*, ed. J. Albani – E. Chalkia. Athens 2013, 210–215.

<sup>81</sup> The conversion of abandoned places of ancient cities (sanctuaries, theatres, marketplaces, houses) into burial grounds is a well known phenomenon of the later 6<sup>th</sup> c. and 7<sup>th</sup> c., see SANDERS, Archaeological evidence (n. 57) 430–431 for the conversion of the Asklepieion in Ancient Corinth into a graveyard. See also ΟΙΚΟΝΟΜΟΥ-LANIADO, Argos (n. 3) 31–32 (Papathanasiou plot) for graves built in the ruins of a Late Antique house and ΤΣΙΒΙΚΙΣ, Μεσσήνη (n. 19) I, 150–152, 180–193 for graves found in the Asklepieion and the Ancient theatre of Messene.

<sup>82</sup> See n. 19. Furthermore, a compilation of small finds so far found in Early Byzantine tile graves in Greece also reveals a 6<sup>th</sup>–7<sup>th</sup> c. date for this grave type, see METAXAS, Schmuck (n. 5).

<sup>83</sup> LIBERTINI, Scavi in Arcadia (n. 10) 227.

to elaborate funerary architecture.<sup>84</sup> In this regard it should also be noted that we do not possess any comparative studies regarding Early Byzantine grave types from Arcadia.

Similarly the fact that Grave 1 contained a collective children's burial was uncommon since in the Early Byzantine period children were usually buried together with adults either in family cist graves<sup>85</sup> or individually in amphorae of the LRA1 and LRA4 types<sup>86</sup> as well as in tile graves.<sup>87</sup> As collective children's burials are not the rule,<sup>88</sup> subsequently the questions of whether the funerary assemblage included in Grave 1 reflects a single episode of sudden loss of children and the necessity of a one-time burial, or whether Grave 1 constitutes a construction made for the successive inhumation of one family's children arose.

The analysis of bone representation and preservation showed that the bones of hands and feet are poorly represented in Grave 1, and the few bones present are almost complete. Bello and Andrews underline the consistent relationship between structural characteristics and the abundance of the small bones of the juvenile skeleton<sup>89</sup> and suggest that the absence or under-representation of sub-adult remains from collective burials should not only be attributed to cultural intervention but also to natural process of decomposition and preservation.<sup>90</sup> However, the discrepancy between the cranium, the femur and the pelvis on the one hand, and the rest of the bones on the other, as well as the good preservation of some ribs and vertebrae, do not conform to the action of intrinsic preservation factors alone. On the contrary, this pattern indicates an inconsistent bone representation that must mainly be attributed to human action while taphonomic agents should have had some additional influence on the preservation of most of the small and fragile skeletal elements. Therefore we propose two hypotheses: 1. Grave 1 was not the original place of inhumation for some of the individuals whose bones have been selected and brought from a different place, probably their original grave; 2. Grave 1 was the original place of inhumation for all individuals and during the reuse of the grave some bones of previous inhumations were selected to be redeposited in the same funerary structure while the rest have been removed from the tomb or were lost (the smaller ones). Unfortunately the poor preservation of the remains does not permit us to conclude which of the two scenarios is accurate.

Secondary treatment of the deceased was not uncommon to the Byzantine society. According to literary sources and archaeological evidence, Byzantine mortuary customs included the transportation of a skeleton or part of it from another grave or the re-deposition of the bones in the same grave

<sup>84</sup> LASKARIS, Monument funéraires (n. 19) 291–302; E. MARKI, Τα χριστιανικά κοιμητήρια στην Ελλάδα. Οργάνωση, τυπολογία, ταφική ζωγραφική, μαρτυρία, κοιμητηριακές βασιλικές. *DChAE* 23 (2002) 163–176.

<sup>85</sup> LASKARIS, Monuments funéraires 288–289.

<sup>86</sup> Everyday Life in Byzantium (n. 4) 538 cat. no. 735 (E. PELEKANIDOU); SANDERS, Archaeological Evidence 428, 431; SKARMOUSOU, Κεραμική (n. 56) 732–733, 738 fig. 3–4; Βυζαντινό Μουσείο Αργολίδας (n. 3) 150 cat. no. 179 (S. METAXAS).

<sup>87</sup> For instance, the tile graves of children found in Argos usually contained one burial, see OIKONOMOU-LANIADO (n. 3), Argos paléochrétienne 28 no. 7, 29 nos. 16–18, 19–20, 32 nos. 14–22; A. OIKONOMOU-LANIADO, Les cimetières paléochrétiens d'Argos, in: Argos et l'Argolide. Topographie et Urbanisme. Actes de la Table Ronde internationale, Athènes – Argos, 28.4.–1.5.1998, ed. A. Pariente – G. Touchais (*Recherches Franco-Helleniques* III). Athens 1998, 408. In only one case, two children were buried together in a tile grave, see A. BAKOUREOU – G. TSEKES, Οικόπεδο Γ. Δεδούση – Ε. Κιρσάνωφ – Γ. Καρακίτσου – Ι. Κοτρωνάκη (Ο.Τ. 14Γ, πάροδος Διομήδους). *AD* 55, B1 (2000) 262 (grave 64). Similar evidence comes from Akraiphnio where only one of 35 tile graves held a burial of two infants, see P. TRITSAROLI, Life and Death at Early Byzantine Akraiphnio, Greece; a biocultural approach. *Anthropologie* 55 (2017) (forthcoming) Pl. 1, grave 13.

<sup>88</sup> A tombstone found in Mazzara del Vallo (Sicily) informs of the burial of three boys aged twelve, ten and eight in 542, see G. MANGANARO, Byzantina Siciliae. *Minima Epigraphica et Papyrologica* IV, fasc. 5 (2001) 131–133 fig. 1. This tombstone could be related to the plague, see D. STATHAKOPOULOS, Crime and Punishment: The Plague in the Byzantine Empire 541–750, in: Plague and the End of Antiquity. The Pandemic of 541–750, ed. L. K. Little. Cambridge 2007, 101. Recently, a grave with the burials of six children was unearthed in Ephesus, see S. LADSTÄTTER – M. BINDER, Byzantine Ephesus. *Current World Archaeology* 82 (2017) 31 fig. 9. These children were not buried all together but at different intervals.

<sup>89</sup> BELLO – ANDREWS, Intrinsic patterns (n. 43) 5.

<sup>90</sup> BELLO – ANDREWS, Intrinsic patterns 11.

in order to free space for the following inhumation.<sup>91</sup> In the case of Grave 1 the crania, pelvis and femora were considered the most significant skeletal elements; as such, secondary manipulation of the deceased included either the transportation of selected bones from elsewhere or the retention of selected bones for reburial in the same grave.

As a result, Grave 1 included the collective burial of at least five individuals aged between 1 and 5 years. The time interval between the deposits cannot be determined, but from the findings it is revealed that they occurred during the 6<sup>th</sup>–early 7<sup>th</sup> c. Concerning the personal objects located in the grave (pl. 3a), several observations can be pointed out. As it has already been noted, a pair of earrings was found on cranium CR5 (pl. 5d–e); their location either indicates that they remained associated with this cranium during the rearrangement of the bones in the grave for the following inhumation or that this individual remained *in situ* and was initially buried with a W-E orientation. Taking into consideration the position of the belt buckle in relation to cranium CR1 (pl. 5c) and the representation of post-cranial elements, we suggest that this corresponds to a primary burial belonging to a 3–5 year old child, possibly being the last inhumation.-

Dental non-metric traits suggest that these individuals were probably relatives; as such, we propose that Grave 1 was the result of a private choice which reflects the desire of the living to gather the very young of the family in the same grave. As these individuals belonged to the first age category (πρώτη ηλικία) described in the Byzantine sources<sup>92</sup>, they had not yet received a formal primary education and were still largely family dependent.

### 3.3. HEALTH STATUS

Dental evidence of physiological stress in childhood and dry-bone manifestation of undernutrition or deprivation is a common find when analyzing immature skeletal remains from archaeological sites. Extensive bioarchaeological literature reports on various diagnostic criteria that are used to differentiate between skeletal lesions associated with vitamin deficiencies in childhood (e.g. scurvy, rickets),<sup>93</sup> genetic (e.g. anemia)<sup>94</sup> or infectious diseases (e.g. osteomyelitis);<sup>95</sup> it must be underlined that sometimes these conditions may co-occur in the same individual. In our study, it would be risky to focus on a single skeletal or dental indicator because of the poor skeletal preservation and unequal representation of the bone elements.

Bearing in mind all the above, some very limited observations can be made. First, porous new bone formation on the squamous portion of the temporal bone is usually considered as indicative of scurvy.<sup>96</sup> In our study however, it is unwise to propose a diagnosis for this lesion recorded on cranium

<sup>91</sup> A. D. KERAMOPOULOS, Παλαιά χριστιανικά και βυζαντινά ταφά εν Θήβαις. *AD* 10 (1926) 126; LASKARIS, Monuments funéraires (n. 19) 278, 280–284; ΚΟΥΚΟΥΛΗΣ, Βυζαντινών βίος και πολιτισμός (n. 57) III, 198; D. NALPANDIS, Cemeteries, Burials, and Burial practices, in: *Everyday Life in Byzantium* (n. 4) 536; B. BAUER – J. MAYRWÖGER – Ch. NEUREITER – S. STÖKL – S. SWIENIEK – J. M. TUZAR, Gräber der byzantinisch-mittelalterlichen Nekropole zu S. Pietro di Deca (Torrenova / ME). Befunde, vorläufige Fundinterpretation, anthropologische Resultate. *JÖB* 61 (2011) 21–63.

<sup>92</sup> A. ΚΙΟΥΣΟΠΟΥΛΟΥ, Χρόνος και ηλικίες στη βυζαντινή κοινωνία: η κλίμακα των ηλικιών από τα αγιολογικά κείμενα της μέσης εποχής (7ος–11ος αι.) (*Istoriko Archeio Ellenikes Neolaias* 30). Athens 1997, 53–54; ΠΙΤΑΡΑΚΗΣ, Material culture (n. 5) 167. Early childhood lasted until the age of 7. A main criterion for its completion was the full development of the permanent teeth and, with, this the ability to speak, see ARIANTZI, *Kindheit* (n. 2) 28–34.

<sup>93</sup> M. BRICKLEY – R. IVES, *The Bioarchaeology of Metabolic Bones Disease*. Oxford 2008, 41–150; C. ROBERTS – K. MANCHESTER, *The Archaeology of Disease*. Stroud 2005, 234–240.

<sup>94</sup> A. LAGIA – C. ELIOPOULOS – S. MANOLIS, Thalassaemia: Macroscopic and Radiological Study of a Case. *International Journal of Osteoarchaeology* 17 (2007) 269–285.

<sup>95</sup> D. J. ORTNER, *Identification of Pathological Conditions in Human Skeletal Remains*. San Diego 2003, 181–206.

<sup>96</sup> C. BOURBOU, Evidence of Childhood Scurvy in a Middle Byzantine Greek Population from Crete, Greece (11<sup>th</sup>–12<sup>th</sup> centuries A.D.). *International Journal of Paleopathology* 5 (2014) 86–94.

CR5 because a large part of it and the entire post-cranial skeleton are missing or cannot be individuated. Second, endocranial lesions on non-adults are of unknown aetiology; as suggested by Lewis<sup>97</sup> these lesions, such as the two cases reported from Ancient Pallantion, should be recorded as non-specific indicators of haemorrhage or infection. Third, teeth showing linear enamel hypoplasia could not be individuated so it is not possible to know how many individuals suffered stressful episodes as evidenced by this lesion. Fourth, post-cranial lesions recorded on long bones cannot be considered specific to a particular disease, although long bone bending deformities and metaphyseal swelling are characteristic skeletal changes for rickets;<sup>98</sup> they can only show that some of these immatures suffered from a disease or infection that lasted long enough to affect the bones. Finally, the young age of the immatures uncovered in this grave suggests that an acute disease or even complications related to weaning possibly contributed to the early death of some of them without leaving traces on the bones.

### 3.4. CLOTHING AND ADORNMENT OF CHILDREN

The personal objects found in Grave 1 – the belt buckle, the pair of earrings and the cross pendant – were of great interest in many regards. First of all, being findings originating from a children's grave, they informed us about children's clothing and adornment, a research field that is still in its infancy as such findings are scarcely published. As gender-specific objects, they further allowed us to archaeologically determine the sex of two children. Finally, these findings also reflect the social and religious background of the family and specifically the parents' practice of adorning children with jewellery and amulets as an expression of love and protection.<sup>99</sup>

In detail, the earrings found in Grave 1 constitute important new evidence on the habit of adorning very young girls with pairs of earrings<sup>100</sup> (pl. 5d–e; 6c–d). This archaeological evidence is corroborated by a notice in Isidore of Seville's *Etymologies*, documenting this practice specifically for *Graecia*.<sup>101</sup> We assume that the specific earrings belonged to the jewellery that children wore during their lifetime and that accompanied them to their grave after death, thus reflecting aspects of girls' everyday material culture.<sup>102</sup> The miniature belt buckle (pl. 5b), in the Early Byzantine period a typical male accessory of the girdle, clearly reflects the fact that those objects were also made for children's tunics (pl. 7a–b). In contrast to the well-known Early Byzantine buckle types of the 6<sup>th</sup>–7<sup>th</sup> c. belonging to male adults, we do not know the exact meaning of these simple buckles worn by children.<sup>103</sup>

<sup>97</sup> LEWIS, Endocranial lesions (n. 49) 95.

<sup>98</sup> BRICKELY – IVES, *The Bioarchaeology of Metabolic* 97.

<sup>99</sup> PITARAKIS, *Material culture* (n. 5) 178, 193–195.

<sup>100</sup> METAXAS, *Schmuck*, nos. 44–45, 49.

<sup>101</sup> Isidoro de Sevilla, *Etimologías Libro XIX. De naves, edificios y vestidos. Introducción, edición crítica, traducción y notas*, ed. M. Rodríguez-Pantoja. Paris 1995, 31.10: *inaures ab aurium foraminibus nuncupatae, quibus pretiosa grana dependuntur. Harum usus in Graecia: puellae utraque aure, pueri tantum dextra gerebant*; ST. A. BARNEY – W. J. LEWIS – J. A. BEACH, OLIVER BERGHOF, *The Etymologies of Isidore of Seville*. New York 2006, XIX.xxxi.10. See also BALDINI-LIPPOLIS, *Oreficeria* (n. 71) 67 with n. 2. This note also reveals the differentiation of boys, who wore a single earring. This habit can be traced from Antiquity to the Modern period in different regions and cultures and with different meanings. For findings of single earrings in Early Byzantine children's graves see Ph. DROSOYANNI, *Μελίσσι*. *AD* 22, B1 (1967) 219; METAXAS, *Schmuck* no. 51. For this habit in the Middle Byzantine period see M. G. PARANI, *Άνδρες με σκουλαρίκια στο Βυζάντιο*, in: 23<sup>ο</sup> Symposio byzantines kai metabyzantines archaiologias kai technes. *Programma kai perilepseis eisegeseon kai anakoinoseon*. Athens 2003, 87; PITARAKIS, *Material culture* 188–190; M. G. PARANI, *Optional Extras or Necessary Elements? Middle and Late Byzantine Male Dress Accessories*, in: DASKALA. *Apodose times sten omotime kathegetria Maire Panagiotide-Kesisoglu (Bibliotheke S. Saripolou 122)*, ed. P. Petridis – B. Foskolou. Athens 2015, 414–419.

<sup>102</sup> See the discussion in PITARAKIS, *Material culture* 194 concerning the adornment of young girls for their burial in the Middle Byzantine period.

<sup>103</sup> For iron buckles from children's graves, see RIFE, *Isthmia* (n. 7) 108 no. 18, 109 fig. 2.100; METAXAS, *Schmuck* nos. 46, 50.

They could just be a functional accessory for girding, but they could also be related to a child's age or social status, if we bear in mind that for the Byzantines the girdle was primarily a symbol.<sup>104</sup> In closing, the cross pendant (pl. 5g) illustrates the parents' tendency to equip their vulnerable offspring with amulets in order to protect them from the evil eye<sup>105</sup> and from the demons<sup>106</sup> which were considered responsible for diseases and the high rate of infant and child mortality.

#### 4. CONCLUDING REMARKS

On the whole, Grave 1, the first systematically and contextually studied funerary assemblage of Early Byzantine Arcadia, contributed in many regards to our knowledge on early childhood displaying aspects of their short life and death, and on the parents' affection towards their vulnerable young ones who did not often survive beyond the age of five.<sup>107</sup> This first age category (πρώτη ηλικία) is biologically the most sensitive social group because of the high mortality related, among other things, to infections, injuries, unhygienic living conditions, malnutrition and to the onset of weaning and its biological adaptations at the age of 3–4 years in the Byzantine society.<sup>108</sup>

This interdisciplinary approach illustrated the significance and value of grave assemblages through their holistic examination; the analysis of archaeological context conjointly with human skeletal remains as well as the interpretation of grave offerings and personal objects consistently enhance our knowledge regarding the funerary practices of the Byzantines towards children, those dictated by social norms and those guided by personal choices, as observed in Grave 1.

#### ACKNOWLEDGEMENTS

The authors are indebted to Dr. Demetrios Athanasoulis, director of the Ephorate of Antiquities of Cyclades and former director of the 25<sup>th</sup> Ephorate of Byzantine Antiquities (responsible for the prefectures of Corinthia, Arcadia and Argolis until 2014), and Dr. Anna-Vasiliki Karapanagiotou, Director of the Ephorate of Antiquities of Arcadia, for the permission to study the grave presented here. Special thanks are owed to the Malcolm H. Wiener Laboratory for Archaeological Science (American School of Classical Studies at Athens) for accommodating the osteological analysis.

Sincere thanks goes to Dr. Alcestis Papadimitriou, Director of the Ephorate of Antiquities of Argolis for the permission to incorporate an unpublished clay jug from the Early Byzantine Northern

<sup>104</sup> See S. ALBRECHT, Warum tragen wir einen Gürtel? Der Gürtel der Byzantiner – Symbolik und Funktion, in: *Byzanz – Das Römerreich im Mittelalter*, Teil 1. Welt der Ideen, Welt der Dinge, ed. F. Daim – J. Drauschke. Mainz 2010, 79–95, for the girdles of the monks, the soldiers, the officials and the rich.

<sup>105</sup> M. W. DICKIE, The Fathers of the Church and the Evil Eye, in: *Byzantine Magic*, ed. H. Maguire. Washington 1995, 9–34; TALBOT, *Death and Commemoration* (n. 3) 290; PITARAKIS, *Material Culture* 196–203.

<sup>106</sup> A female demon of Late Antiquity connected to the death of newborns was *Obizuth*, see Ch. Ch. McCOWN, *The Testament of Solomon* edited from manuscripts at Mount Athos, Bologna, Holkham Hall, Jerusalem, London, Milan, Paris and Vienna. Leipzig 1922, 43–44\*, XIII, 3: Ὁβυζούθ, ἥτις ἐν νυκτὶ οὐ καθεύδω, ἀλλὰ περιέρχομαι πάντα τὸν κόσμον ἐπὶ ταῖς γυναῖξι, καὶ στοχαζομένη τὴν ὄραν μαστεύω καὶ πνίγω τὰ βρέφη [...]. The female demon of the Byzantine and Post-Byzantine era killing newborns is *Gyllo/Gello*, see R. P. H. GREENFIELD, Saint Sisinnios, the Archangel Michael and the Female Demon Gylou: the Typology of the Greek Literary Stories. *Byzantina* 15 (1989) 83–142; TALBOT, *Death and Commemoration* 290–291. See also ARIANTZI, *Kindheit* (n. 2) 299–324 for the parent's belief that diseases were caused by demons.

<sup>107</sup> TALBOT, *Death and Commemoration* 306.

<sup>108</sup> C. BOURBOU – S. J. GARVIE-LOK, Breast feeding and Weaning Patterns in Byzantine times. Evidence from Human Remains and Written Sources, in: *Becoming Byzantine* (n. 1) 65–83; C. BOURBOU – B. T. FULLER – S. J. GARVIE-LOK – M. P. RICHARDS, Nursing Mothers and Feeding Bottles: Reconstructing Breastfeeding and Weaning Patterns in Greek Byzantine Populations (6<sup>th</sup>–15<sup>th</sup> centuries AD) Using Carbon and Nitrogen Stable Isotope Ratios. *Journal of Archaeological Science* 40 (2013) 3903–3913.



cemetery of Argos in this study; to Margarita Sofou, metal conservator (Archaeological Museum of Argos), for the restoration of the metal findings as well as for specialized bibliography concerning the corrosion products on the bones; to Dr. Anastasia Vassiliou (Ephorate of Antiquities of Argolis) and Dr. Voula Konti (National Hellenic Research Foundation) and the anonymous reviewers for useful remarks concerning the historical and archaeological part, as well as to Dr. Ioanna Moutafi (The M. H. Wiener Laboratory for Archaeological Science, ASCSA) for her comments and suggestions on the osteological part of the paper. The authors also wish to thank Theoni Christofilou and Dr. Eleni Psathi (Ephorate of Antiquities of Arcadia) for their administrative assistance and, in particular, Yanis Karamatzanis (Nafplio) for editing the English text.



Plate 1a  
Location of Pallantion in regard to the major routes and cities of the Peloponnese according to the Tabula Peutingeriana

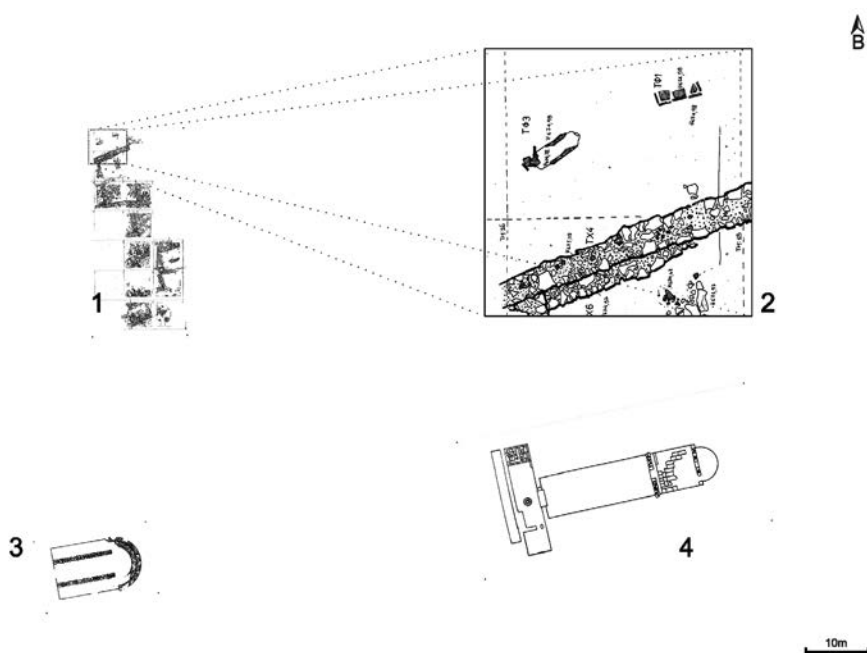

Plate 1b  
Plan of the Early Byzantine remains in the Bataki field unearthed in 1940 and 2009

1 Remains of Late Antique/Early Byzantine houses in the excavation sector Z.

2 Section with the location of the Early Byzantine children's graves.

3 Foundation of the Early Christian basilica of Hag. Georgios.

4 Foundation of the Early Christian basilica of Hag. Christophoros



Plate 2a–d: Grave 1

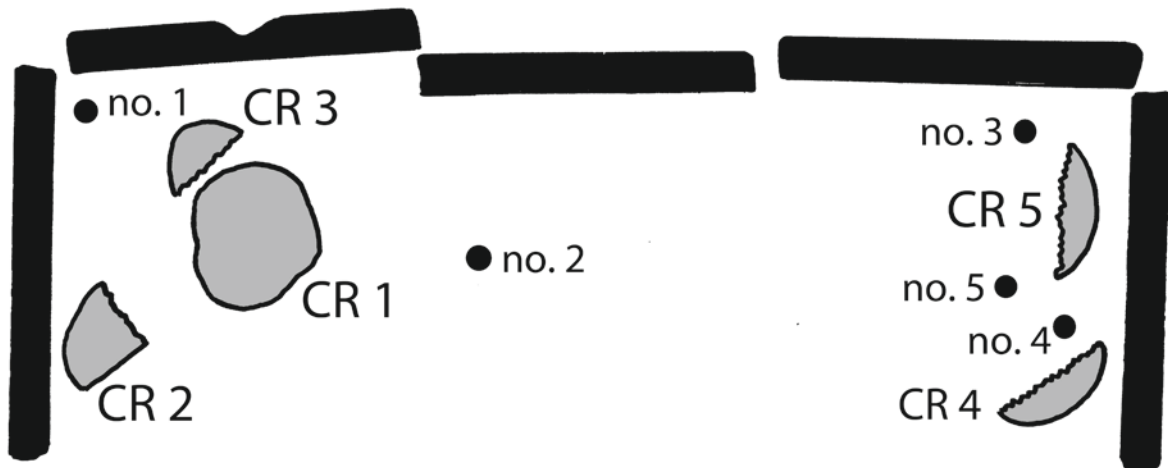

Plate 3a: Position of cranial fragments (CR1-5) and findings (nos. 1-5) – 1:10

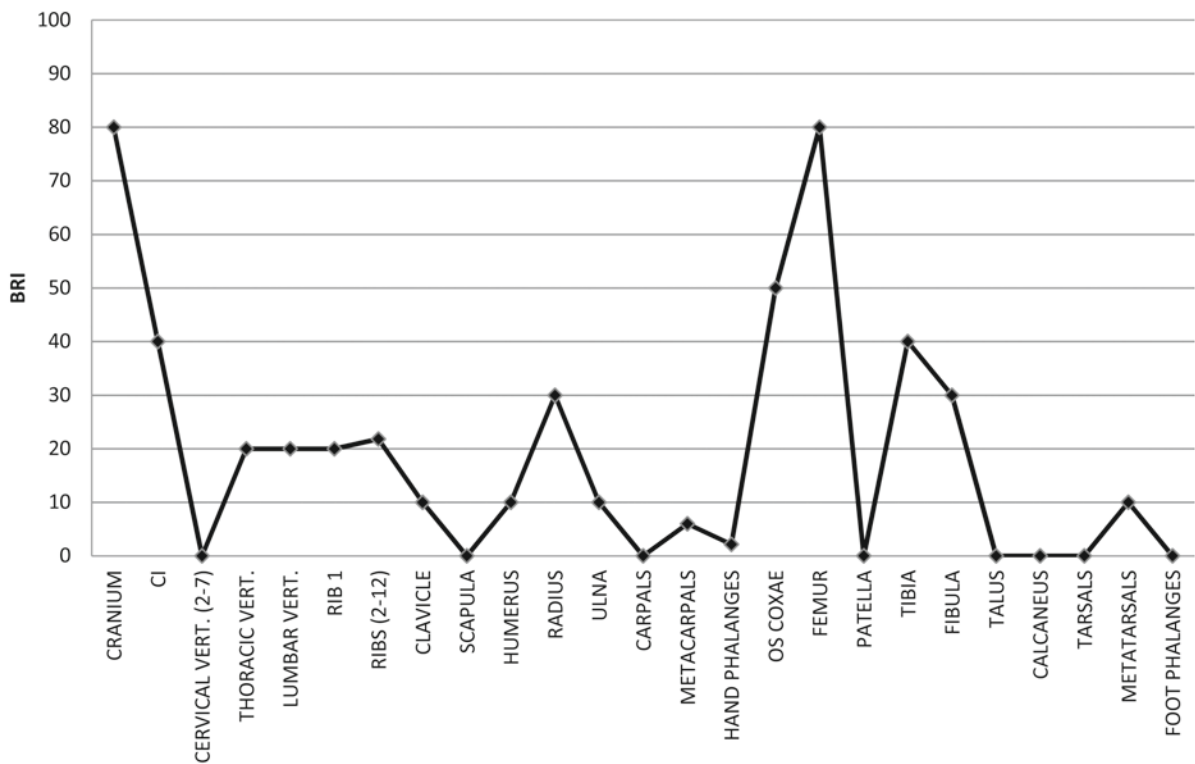

Plate 3b: Bone Representation Index (MNI=5)



Plate 4a: First permanent molars with dental enamel hypoplasia and Carabelli's trait

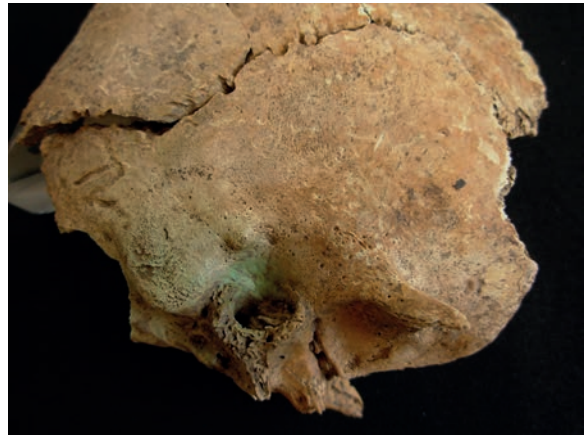

Plate 4b: New bone formation covering the exterior surface of the right temporal bone (CR5)

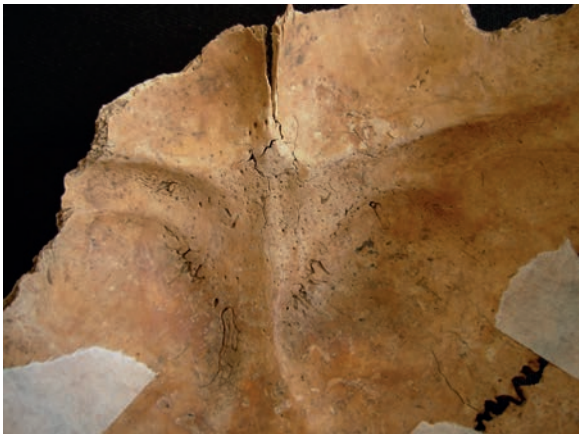

Plate 4c: Porous lesions and vascular impressions on the endocranial surface of the occipital bone (CR2)



Plate 4d: Abnormal porosity on the anterior surface (medial aspect) of a right tibia



Plate 4e  
Flared distal metaphysis on the left intact femur



Plate 4f  
Anteroposterior incurvation on the left intact femur



Plate 5a: Clay jug (no. 1) – 1:1



Plate 5b  
Copper alloy belt buckle (no. 2) – 1:1

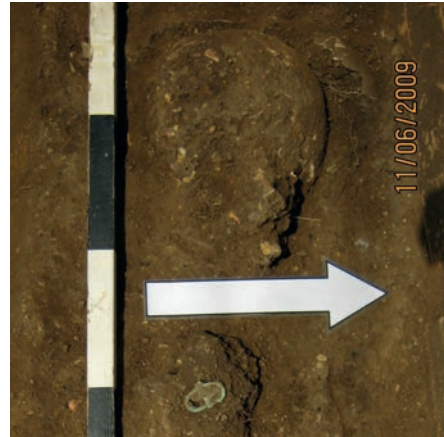

Plate 5c: Cranial fragment CR1 and belt buckle *in situ*



Plate 5d-e: Silver alloy earrings belonging to cranium CR5 (nos. 3-4) – 1:1



Plate 5g  
Silver-plated cross pendant (no. 5). – 1:1

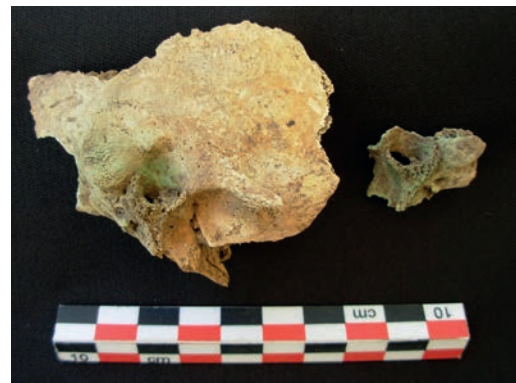

Plate 5f  
Green staining on two symmetrical, right and left, mastoid processes and external acoustic meatuses belonging probably to the same individual and indicating the presence of earrings



Plate 6a  
Cross pendant from a cist grave, Early Byzantine  
Northern cemetery of Argos – 1:1



Plate 6b  
Miniature belt buckle from the 6<sup>th</sup>/7<sup>th</sup> c. assemblage found  
in the Andritsa cave in Argolis – 1:1



Plate 6c–d: Pairs of copper alloy (c) and silver (d) earrings  
from girls' tile graves,  
Early Byzantine Northern cemetery of Argos – 1:1



Plate 6e  
Clay jug from a cist grave, Early Byzantine Northern cemetery of Argos – 1:2



(above) Plate 7a  
Child's tunic (H 48 cm) from Egypt, Early–Middle Byzantine period



(left) Plate 7b  
Depiction of a boy wearing a belted tunic. Wall painting from the so-called tomb of Eustorgios, Thessaloniki, 4<sup>th</sup> c.